

2015

Smart Fuel Tank Sensor

EE491 SENIOR DESIGN – DESIGN DOCUMENT – GROUP 1627

GROUP MEMBER: YINKUN PENG, XIAYANG SUN, KELLY MCCONVILLE

ADVISOR: RANDY GEIGER

Problem Statement: The goal of our project is to create a gasoline tank sensor that will take a measurement from outside of the tank, thus making it safer by eliminating all electrical components from inside the tank. This sensor needs to be accurate (at least to 10% accuracy) and cheap enough to be mass produced.

Assessment Criteria

There were a number of other factors that we considered when researching and assessing different methods. For example, because we desired a method that could be realistically implemented cost was big factor. Although the traditional method of a float is inaccurate, it is very cheap to implement so our method needs to be as well. An additional fault of the float method is that it can be very difficult to fix/replace so we wanted a method that was easily accessible and replaceable. Finally, because not a gasoline tanks are the same size or shape a method that could get the liquid level and was not dependent on the geometry of the tank was desired.

Assessed Methods

Float Method

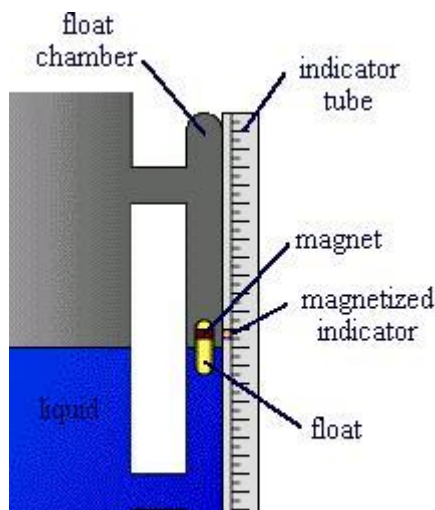

Figure 1: Traditional float method for liquid level sensing

There a few different ways that the float method can be implemented but they all rely on some float inside of the tank that moves up and down with the level as gasoline.

This is a fairly accurate and simple method to implement. However, we found two problems with this method. The first problem is that it would require a redesign of the shape of the tank. The other problem that we found with this method is that we need some way to track the position of the float which would likely

require a servo. This would be a very expensive solution to a problem that requires a cheap one which is why this method was ruled out.

Capacitance Method

This is a very common method for liquid level sensing. It relies on the property of capacitance and the fact that capacitance is proportional to the amount of gasoline in the tank. There are several benefits to the capacitance method. The measurement can be taken from outside of the tank and is very accurate therefore meeting our two most important criteria. The only detriment to this method is that it is still somewhat reliant on the geometry of the tank, but it could be easily configured to the specific tank for an accurate reading.

Load cell method

Load cell sensors are very popular in measuring tank weight. By reading the measured weight, we can know the difference of liquid in the tank because the weight of the tank is proportional to the liquid level inside of the tank. This method also matches our requirement to put all sensors outside of the tank. The advantage why we chose this method a load cells are inexpensive, easy to implement but also very stable and accurate.

Thumper method

According to our research, thumper method is not common but effective to measure liquid level. In this method, we can generate the frequency of vibration of tank wall by knocking on the surface of the fuel tank with a thumper. Theoretically, the frequency will be different as the fuel level inside the tank

changes. The method also meets the requirement of taking measurements outside the tank. Designing the fuel tank sensor in this way will also guarantee low budget and measuring accuracy.

Modeling Viable Prototype Methods

Capacitance modeling

For the purpose of modeling our capacitance method we'll assume we're trying to find the liquid level of the one-gallon gas tank as seen in Figure 2.



Case 1:

This is the most trivial case. Assume that we have two parallel plates with heights of 4.5 inches and widths of 10 inches each (area of .0058 meters squared) and these plates are separated by 6.5 inches (the width of the tank).

*Figure 2: One gallon gas tank
11.5"x6.5"x4.5"*

We will also assume that there is only water between these plates, which has a dielectric constant of $70C^2N^{-1}m^{-2}$. Finally, we will be neglecting fringe capacitance in this case.

Using the following equation then we can find the capacitance between the two plates

$$C = \frac{k\epsilon_0 A}{d}$$

In this case then the capacitance is the following

$$C = \frac{70N^{-1}m^{-2} * 8.854x10^{-12} * (.029m^2)}{.165m} = .109pF$$

Case 2:

This case is the same as Case 1 except we will assume that the space between the plates is empty. So the only thing that we will change for this example is the dielectric constant which will now be that of air ($1N^{-1}m^{-2}$).

$$C = \frac{1N^{-1}m^{-2} * 8.854x10^{-12} * (.029m^2)}{.165m} = .0015pF$$

Case 3:

This is a case closer to our real life example. We now have a combination of both gasoline and air in tank (with the height of the gasoline of θ making the height of the air $1 - \theta$).

$$C = \frac{k_{gasoline}\epsilon_0w(\theta)}{d} + \frac{k_{air}\epsilon_0w(1 - \theta)}{d}$$

We can solve this equation then to find the height of gasoline, θ :

$$\theta = \frac{\frac{Cd}{\epsilon_0} - k_{air}}{k_{gasoline} - k_{air}}$$

Knowing the height of the gasoline and the height of the tank it is trivial to find how full the tank is as a percentage. The above examples are a simplification as we are not accounting for fringe capacitances or the capacitance of the polyethylene gas tank, but it shows how this method can be applied to determine liquid level with high accuracy.

Case 4: In practice the capacitance between two parallel plates on each side of a gasoline tank would be far too small to use. Putting this method in to practice will require that the capacitors be at an angle

(likely close to perpendicular). As found by Bueno-Barrachina, Canas-Penuelas, and Catalan-Izquierdo [1], this capacitance can be found by the following equation:

$$C = \frac{\epsilon_0 \epsilon_1}{\alpha} \ln\left[1 + \frac{l}{d}\right]$$

Load cell modeling

To model this method, it's pretty dependent on the geometry of the tank. Right now, we just considering experimental purpose, so the commonly used tanks are cylinder or rectangular.

Case 1: Cylinder tank:

Because the bottom of the cylinder is round, it is hard to find the stable points on a complete round.

Therefore, we need a triangle structure at the bottom of the cylinder, and put one load cell at each angle of the triangle structure, which means totally three load cells. The ideal design is just below:

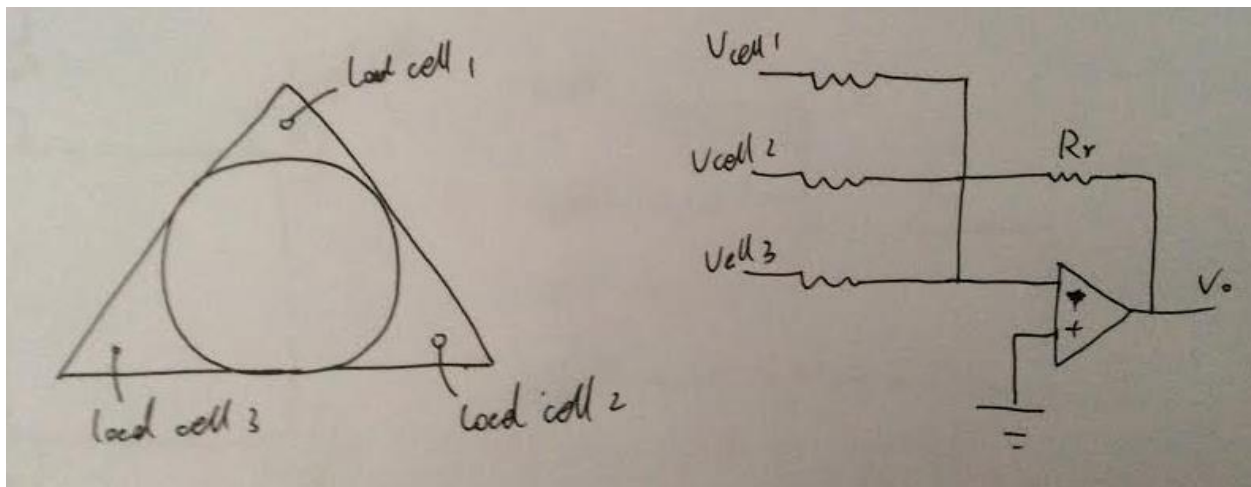

Figure 1: round tank base

On the right side of the design figure is the circuit model for three load cells. Vout is the total output voltage from load cells and that's all signals we have from measurement. The rest part need to be done by the microcontroller of computer.

$$V_{out} = R_r \times (I_{cell1} + I_{cell2} + I_{cell3})$$

After we can detect the output voltage, we can do some experiments to find out the relationship between voltage and the liquid level.

Case 2: Rectangular tank

Due to the rectangular shape, we just make the four corners as the support points because they are stable and easy to find. Totally use four load cells. The ideal design is as below:

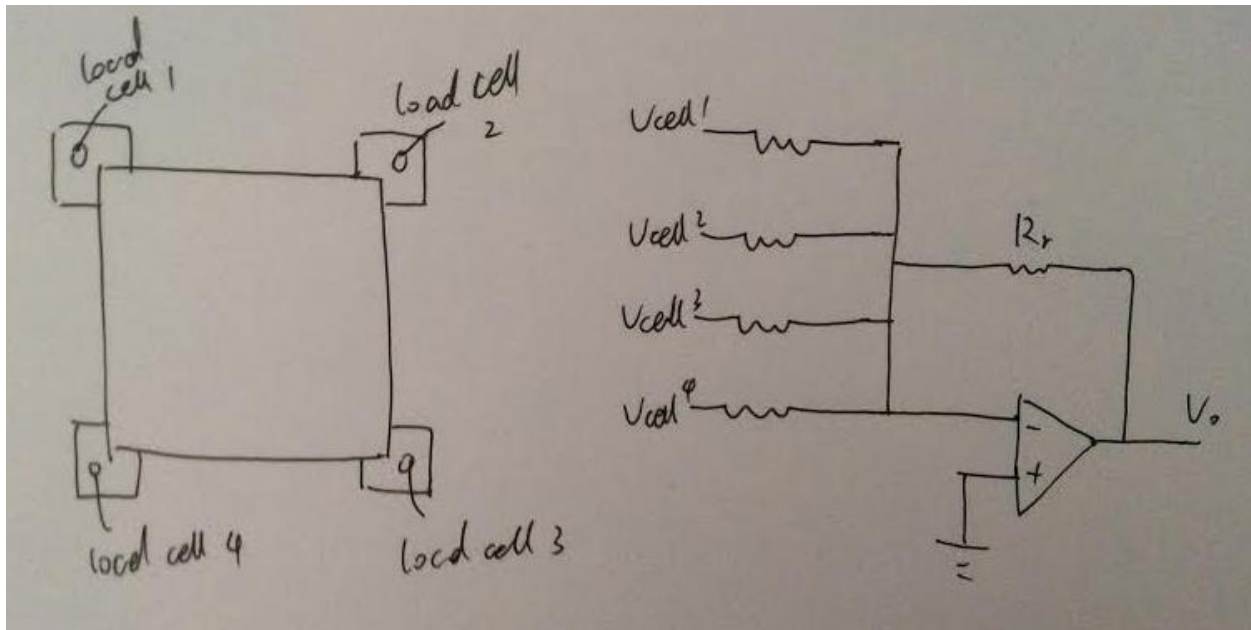

Figure 2: Rectangular tank base

It's pretty much the same as the three load cells design, but just add one more load cell. The equation:

$$V_{out} = R_r \times (I_{cell1} + I_{cell2} + I_{cell3} + I_{cell4})$$

After we can detect the output voltage, we can do some experiments to find out the relationship between voltage and the liquid level.

Thumper Modeling

In this method, we will plot the digitized signal with the help of a microphone, a low pass filter, an analog-to-digital (A-to-D) converter. We then will do numerous experiments before finding the relationship between (the frequency where the largest magnitude occurs in the spectrum) and the fuel

level inside the tank. Every time the fuel level changes, we will create a corresponding spectrum and find the dominant frequency in the spectrum.

One example of the digitalized signal plotted by Matlab is shown below:

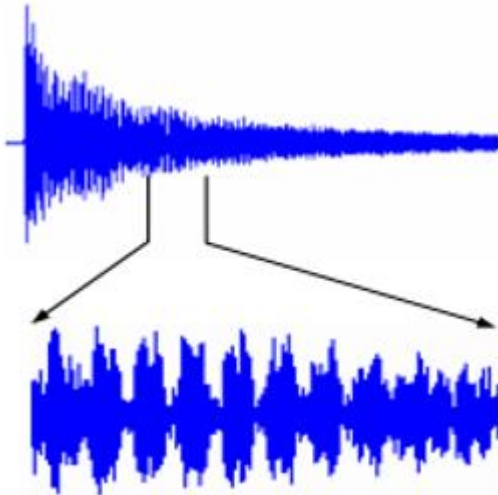

Figure 1: Sample digitalized signal

Case 1:

When the gasoline is almost full inside the tank, we can get the spectrum:

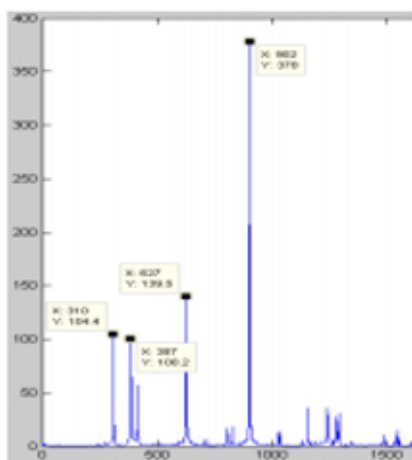

Figure 2: Spectrum when the tank is full

According to the spectrum, we can determine the dominant frequency is about 900 Hz.

Case 2:

When the gasoline is half-full inside the tank, we can get the spectrum:

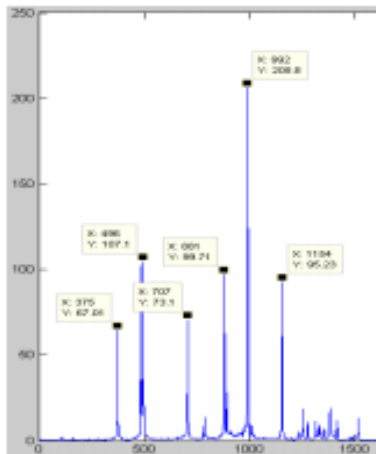

Figure 3: Spectrum when the tank is half-full

Based on the spectrum, we can determine the dominant frequency is about 1000 Hz.

Case 3:

When the gasoline is almost empty inside tank, we can get the spectrum:

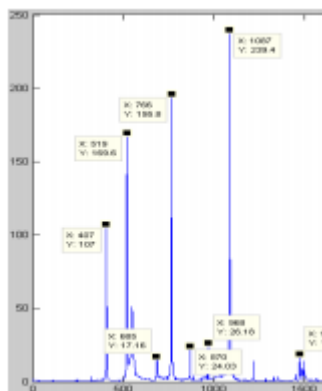

Figure 4: Spectrum when the tank is empty

Based on the spectrum, we can determine the dominant frequency is about 1100 Hz.

We have found an initiatory relationship between the level and dominant frequency. That is the more gasoline remaining in the tank, the lower dominant frequency will be. We still need more experiments in order to make our sensor more accurate in the future.

Prototyping

Capacitance Method

The capacitance method is relatively simple to prototype. We can put two plates on either side of a tank and knowing the dimensions of the tank as well as the dielectric constant of the tank, gasoline, and air/fumes we can accurately get the liquid level inside of the tank.

One way to accomplish this would be by connecting our capacitors to a microcontroller and performing a capacitance to digital conversion. We can then calculate the liquid level based on the capacitance value and perhaps output the value to an LCD screen. This would be a relatively simple way to create a working prototype / proof of concept that would be very similar to what we be implemented in reality and very accurate.

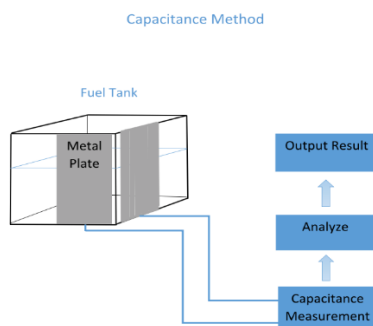

Load Cell Method

The load cell method should be the easiest way to prototype. Basically, just install three or four load cells under the triangle structure or rectangle structure. Then connect all load cells to the microcontroller. Some

microcontroller has the LCD screen. We first need to do experiment to find out the relationship between the output voltage signal and the height of liquid level. Then we can code the microcontroller to directly show the liquid level.

After a very large number of experiments, we believe the relationship should be consistent so the measurement should be accurate and reliable.

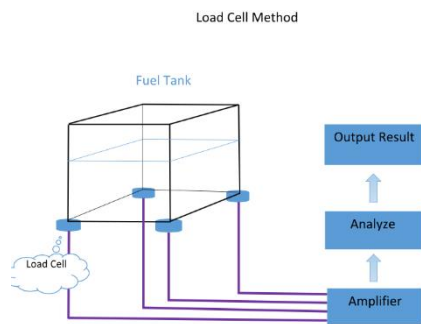

Thumper Method

When prototyping the thumper method, we also need several components: a microphone, a low pass filter, an analog-to-digital (A-to-D) converter, and a computer. Firstly, we need a hammer, which is for knocking on the surface of the tank and generating the frequency of vibration. Then we will use a microphone to record the signal. After that, we process the signal by a low pass filter, and convert the signal to digital format by using A-to-D converter. Then we can use Matlab to get the spectrum using fast Fourier Transform. Lastly, we can determine the relationship between the dominant frequency and the fuel level inside the tank. That is how we measure fuel level by analyzing the spectrum.

Project Contributions

Kelly McConville: Webmaster. Along with Yinkun and Xiayang researched and analyzed viable liquid level sensing methods with a majority of research done focusing on floats and capacitance. I will be in charge of prototyping the capacitance method as well as writing code for the other two prototypes.

Yinkun Peng: Team leader. Team up with Kelly and Xiayang. I have done a lot of researches of published patterns on measuring liquid level of all kinds of methods. Then discuss with team members and mentor

and finally we found three ways to approach. My major focus is the load cell method. Also, I will try to help as much as can for the other two prototypes.

Xiayang Sun: In charge of writing weekly reports. I did many researches, and found some articles and patents about liquid level measurement. We came up with three potential methods for implementing our project. I will be in charge of testing the thumper method. After finishing my job, I will help my teammates with other two methods.

References

[1] Bueno-Barrachina, J.M., C.S Cañas-Peñuelas, and S. Catalan-Izquierdo. "Capacitance Evaluation on Non-parallel Thick-Plate Capacitors by Means of Finite Element Analysis." *Journal of Energy and Power Engineering* 5 (2011): 373-78. Web.

Implementation

Load cell method:



As the figures show above, our final implementation of the structure base composed of two plate, one on the top of the other one. Placed a rod at one side of the bottom plate and only one load cell at the other side.

Finally we decided to use only one load cell because the budget, the sensor we purchased is half bridge and up to 50 kg. In order to give more strain to one sensor to get more signals, we used only one. Also, it's hard to put two sensors which in the stable condition.

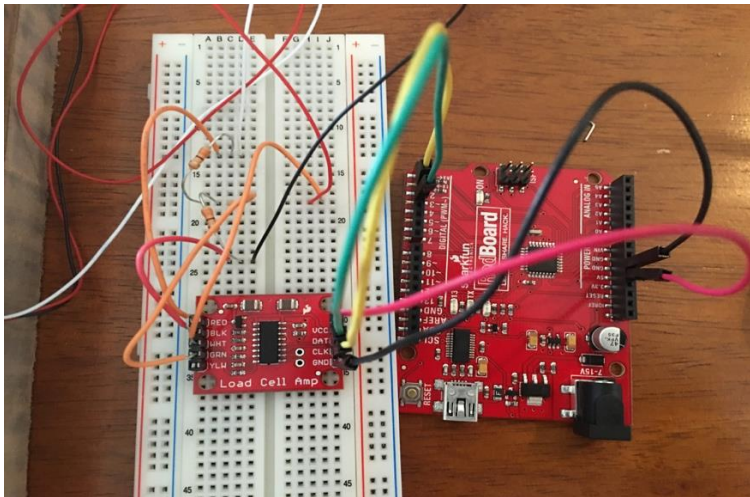

The above figure shows how I connect the sensor to the circuit. I used two 300 Ohms resistors to build a full Wheatstone bridge, then the output goes to the amplifier, then the amplifier goes to the Arduino.

Capacitance method:

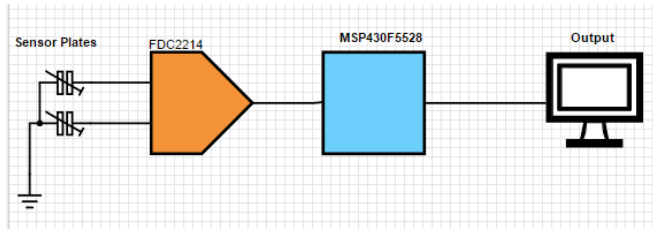

The capacitance prototype consists of two metallic plates on the bottom and side of a polyurethane tank. The plates are connected to the TI FDC2214 evaluation model, which consists of a capacitance to digital converter as well as a MSP430F5528 microcontroller. TI

sensing software reads the capacitance values from the microcontroller and then a java program converts the capacitance values to a liquid level. The plates are protected from outside capacitances by Styrofoam insulation that covers the outside of the tank.



Testing

Load Cell Method:

The testing process is basically select one calibration factor and then find the relationship between the output with the actual liquid level. The followings are two sample testing result:

gallon	display	should be	factor
0	0.1	0	-88888
0.5	0.5	0.5	
1	0.9	1	
1.5	1.4	1.5	$y = 0.7964x + 0.1364$
2	1.8	2	
2.5	2.1	2.5	
3	2.6	3	
3.5	2.9	3.5	
4	3.3	4	
4.5	3.7	4.5	
5	4.1	5	

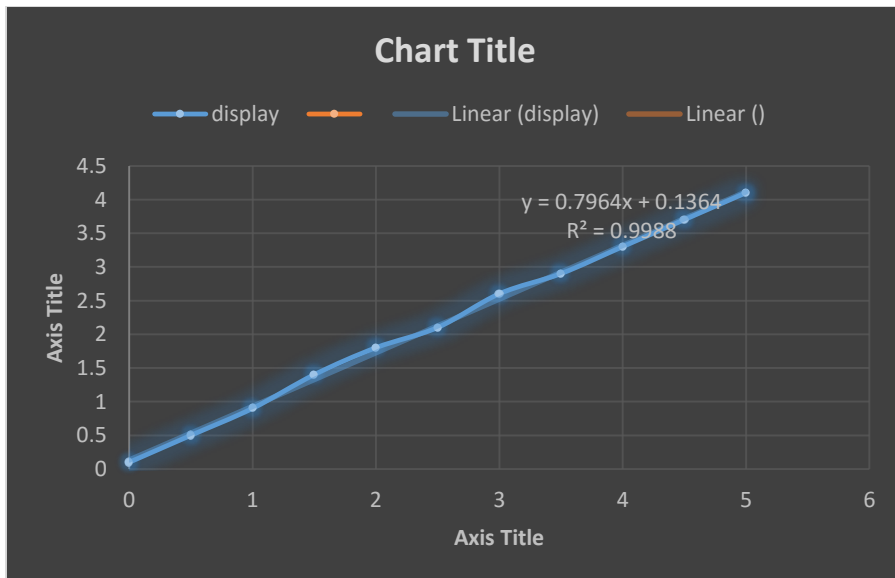

SMART FUEL TANK SENSOR- GROUP 1627

gallon	display	should be	factor
0	0	0	-58888
0.5	1	0.5	
1	1.7	1	
1.5	2.4	1.5	
2	3.1	2	
2.5	3.8	2.5	
3	4.4	3	
3.5	4.7	3.5	
4	5.2	4	
4.5	5.6	4.5	
5	6.1	5	

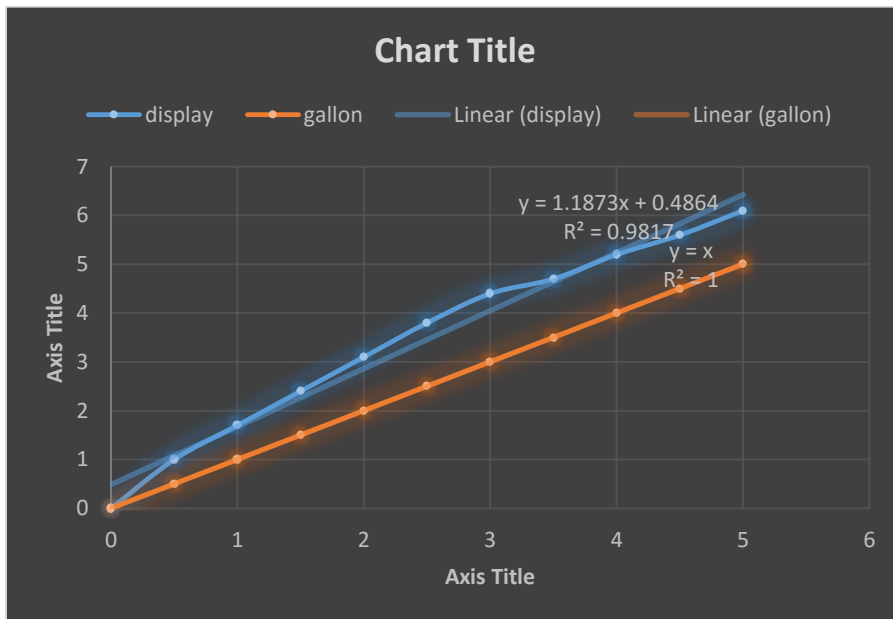

After we tried a lot of calibration and test, finally we make the result as following. Which the errors are within plus or minus 0.15 gallons.

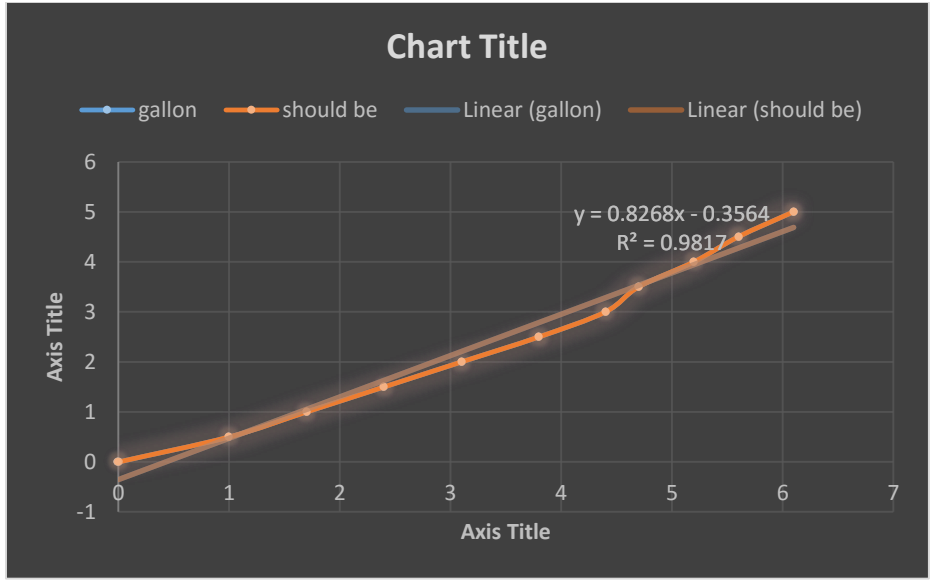

Capacitance method:

There is a very strong correlation between the capacitance and the amount of liquid in the tank. The capacitance value can be measured to within .05 gallons in a 5 gallon tank, or 1%.

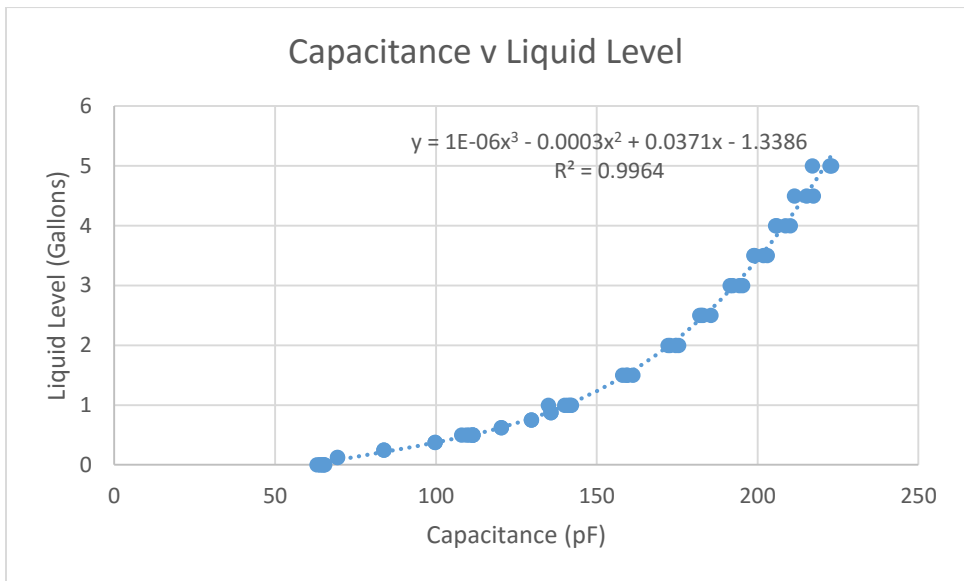

Appendix I : Operation Manual

Load Cell Method:

1. First connect the way as we described before,
2. Load codes to the Arduino
3. Calibrate it as zero when there is only the empty tank setting on the plate
4. Add half gallon of water into the tank, then check the output
5. Add another half gallon of water into the tank, then check the output
6. Repeat the same steps until the tank is full
7. Get the relationship between the output and actual liquid level of the tank
8. Take the relationship into the code

Capacitance Method:

Requirements:

- Java SE
 - TI Sensing Solutions EVM GUI
1. Connect the USB cable from the microcontroller to the computer.
 2. open the TI Sensing Solutions EVM and change the configuration to output on channel 2
 3. click data streaming and select a log file.
 4. Start data streaming.
 5. Open the Java program and make sure the name of the file matches.
 6. Start the Java program to output the measure the amount of liquid in the tank.

The program is now correctly measuring the liquid level. To test that it is working correctly, simply pour **water** in the tank check that the output value matches the amount of water that was poured.

Appendix II

We have approached one more method, which we named it thumper method.

Thumper Method : When prototyping the thumper method, we also need several components: a microphone, a low pass filter, an analog-to-digital (A-to-D) converter, and a computer. Firstly, we need a hammer, which is for knocking on the surface of the tank and generating the frequency of vibration. Then we will use a microphone to record the signal. After that, we process the signal by a low pass filter, and convert the signal to digital format by using A-to-D converter. Then we can use Matlab to get the spectrum using fast Fourier Transform. Lastly, we can determine the relationship between the dominant frequency and the fuel level inside the tank. That is how we measure fuel level by analyzing the spectrum. The group member who was in charge of the capacitance prototype dropped out of our group, however, so we have no results to report at this time.

